

BD50

CRAWLER DOZER



Salient Features :

- BEML BS6D105 Engine
- Spur gear, double reduction Transmission
- Sturdy Construction
- Groove-type Floating Seals



Flywheel horsepower (net) : 67kW (90hp) @ 1750 rpm

Operating mass : 11000 kg
(with angle dozer)

BD50

BD50

CRAWLER DOZER

Salient Features :

- ★ Diesel Engine : Turbo-charged, Direct-injection system for high fuel efficiency and for cleaner exhaust. Can work up to 4500m altitude without fuel adjustment.
- Main frame and steering case welded into a rigid monoblock construction.
- Wet type main clutch hydraulically boosted and foot controlled for light touch and smooth operation.
- Unit construction of engine, clutch and transmission assemblies for quicker and easier servicing and overhaul.
- Reduced maintenance time and costs as well as extended serviceability of undercarriage assured with floating seals in oil filled rollers, sprockets and idlers.
- Dust seals located between link bushing and pin prevent entry of abrasive dirt or mud and ensure long track life.



ENGINE

Make	BEML
Model	BS6D 105
Type	Water cooled, 4 cycle turbo charged, direct injection diesel engine
No. of Cylinders	6, inline
Bore x Stroke	Dia 105 x 125 mm
Displacement	6490 cc
Horse Power	
Rated bhp*	74.5 kW (100 hp) @ 1750 rpm
Flywheel power**	67 kW (90hp) @ 1750 rpm
Maximum torque	47.5 kg-m @ 1100 rpm
Fuel System	
Type	Bosch type, FIP system
Governor	Mechanical, all speed control
Lubrication system	
Method	Forced lubrication
Pump	Gear pump
Filter	Spin-on cartridge paper element
Oil Cooler	Water cooled
Cooling system	
Type	Centrifugal water pump pusher type fan
Air Cleaner	
Type	Dry, horizontal type
Electricals	
Alternator	24 V, 45A
Starting motor	24 V, 7.5 kW
Battery	2 x 12 V, 150 Ah

* Rated bhp is the output of the engine as installed in the machine at governed rpm and with engine manufacturer's approved fuel setting. Accessory losses included are water pump, fuel pump and lube oil pump. Output guaranteed within $\pm 5\%$

** Flywheel power is the rated BHP less the average accessory losses. Accessories included are fan, alternator and hydraulic pump at no load.



POWER TRAIN

Transmission			
Type	Direct drive		
Main Clutch Type	Wet, double disc spring type with inertia brake, foot operated and hydraulic booster.		
Transmission Type	Spur gear, selective sliding, splash lubricated and hand operated.		
Final Drive			
Type	Spur gear, double reduction		
Reduction ratio	10.07		
Gear Shift	4 forward, 3 reverse		
Travel speeds km/h			
Range	Forward	Drawbarpull (kg)	Reverse
1st	0 - 2.5	8280	0 - 3.2
2nd	0 - 3.5	5920	0 - 5.2
3rd	0 - 5.5	3770	0 - 8.0
4th	0 - 9.4	2210	
Max. Drawbar pull	10,340 kg		

STANDARD ACCESSORIES

Tachohourmeter	Key switch
Ammeter	Back - up switch
Engine Oil Pressure Gauge	High water temperature indicator
Water temperature guage	Light switch
Head lamps & rear lamp	Low engine oil pressure indicator
Charger indicator	4st relay, battery relay
Back - up alarm	Tool kit
24 V, (12 V x 2) 150 Ah batteries	Canopy canvas

OPTIONAL ATTACHMENTS

Rake Dozer	Towing winch
Reduced width blade	Multi - shank ripper
Drawbar (fixed type)	Cold start kit
500 mm shoe	Steel Cabin



HYDRAULIC SYSTEM

Hydraulic Pump

Type	Gear pump
Capacity	170 ℓ / min @ 1750 rpm
Relief pressure	140 kg / cm ²

Hydraulic Cylinders

Type	Double acting piston
Blade lift	2 cylinders
Bore x Stroke	Dia 90 x 883 mm



STEERING

Steering Clutch

Type	Dry, multiple disc, spring type
Control	Hand operated with spring booster

Steering Brake

Type	Dry, contracting band
Control	Hand operated
Min. turning radius	2.7 m



UNDER CARRIAGE

Suspension	Semi - rigid equalizer bar type
Track Frame	Box section, high tensile strength steel construction
Track Rollers	5 No. each side
Carrier Rollers	2 No. each side

Track Shoes

Type	Assembled, single grouser
Grouser Height	50 mm
Shoe width	400 mm
No. of shoes	38 on each side
Ground pressure (Tractor only)	0.55 kg / cm ²
Ground contact area	16,700 cm ²
Gradeability	30°



BLADE ATTACHMENT

	Angle Dozer	Straight Dozer
Overall length with dozer (mm)	4700	4455
Blade length x height (mm)	3350 x 910	2760 x 990
Max. lift above ground (mm)	1050	930
Max. drop below ground (mm)	380	445
Max. tilt adjustment (mm)	250	250
Digging angle (degrees)	55	55
Additional ground Pressure (kg / cm ²)	0.108	0.109
Mass (kg)		
Dozer attachment	1470	1495
Hydraulic control unit	330	330

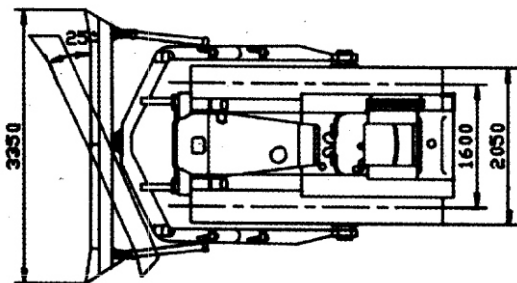

Ground Clearance : 350 mm

Material and specifications are subject to change without notice, Illustrations may include optional equipment & accessories



OPERATING MASS

Mass of tractor only (including rated capacity of lubricant, coolant and fuel)	10000 kg
--	----------



COOLANT AND LUBRICANT CAPACITY (Refill)

System (refilling)	Capacity in ℓ
Cooling System	35
Engine oil pan	24
Fuel Tank	240
Main Clutch	15
Transmission bevel gear case	34
Final Drive (each side)	12
Hydraulic tank	49



DRAWBAR PULL Vs TRAVEL SPEED

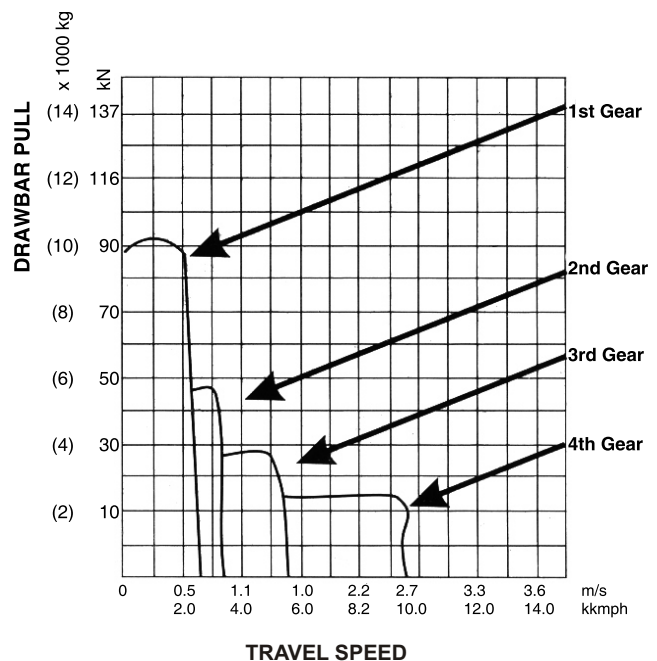

Note : The drawbarpull and travel speed may vary depending on the ground conditions and machine weights.

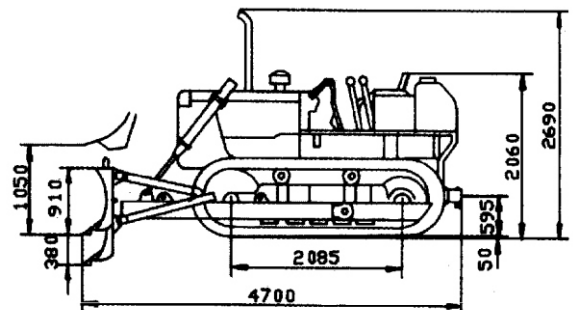

बी ई एम एल लिमिटेड BEML LIMITED

A Govt. of India Miniratna Company Under Ministry of Defence

Business Network

Corporate Office

BEML Soudha, 23/1, 4th Main,
S.R. Nagar, Bangalore-560 027

T + 91 80 22963240, 22963250

F + 91 80 22963278/516/280/164

E-mail: office@cpd.beml.co.in
office@pr.beml.co.in

International Business Division

BEML Soudha, 23/1, 4th Main,
S.R. Nagar, Bangalore-560 027

T + 91 80 22222730, 22233350
22963187, 22963215

F + 91 80 22224874

E-mail: office@export.beml.co.in

Marketing Division

5th Floor, Unity Building,
J.C. Road, Bangalore-560 002

T + 91 80 22963501/02/07/510/553

F + 91 80 22963541

E-mail: m@beml.co.in
bemldealer@dealer.beml.co.in

Global Service HQ

C-6, Central Hingna Road,
MIDC Industrial Area, Hingna,
Nagpur-440 028

T + 91 7104 287097/287098

F + 91 7104 287099

E-mail: ss.servicehq@gmail.com
ss@servicehq.beml.co.in

REGIONAL OFFICES

Bangalore

No -23/1, Haudin Road Cross,
Ulsoor Road, Bangalore - 560008
Karnataka

T + 91 080 22963590/92/93/94
F + 91 080 2558156
E-mail: mg@beml.co.in

Bilaspur

1/A, Sector-C, Srigitti Industrial Area,
P.O: Tifra, Bilaspur - 495 223.
Chhattisgarh.

T + 91 7752 252745, 252598
F + 91 7752 252065
E-mail: bilaspur@rm.beml.co.in

Chennai

Flat No. 10&11, Supriya Estates,
Sterling Road, Nungambakkam,
Chennai - 600 034, Tamil Nadu

T + 91 44 28276576 / 22820844
F + 91 44 28257319
E-mail: chennai@rm.beml.co.in

Dhanbad

Kamal Kunj, Kola Kusuma,
Saraidhela, Dhanbad - 828 127
Jharkhand

T + 91 326 2200180 / 2208982/5827
F + 91 326 2200182
E-mail: dhanbad@rm.beml.co.in

Hyderabad

3-6-114, Himayat Nagar,
Hyderabad - 500 029
Andhra Pradesh

T + 91 40 23225250 / 7032 / 2166
F + 91 40 23221794
E-mail: hyderabad@rm.beml.co.in

Kolkata

35/1, Taratala Road,
Kolkata - 700 088.
West Bengal

T + 91 33 24015286 / 87 / 98 / 99
F + 91 33 24015288
E-mail: kolkata@rm.beml.co.in

Mumbai

C/o Richardson & Cruddas (1972) Ltd.
3rd Floor, Corporate Office Building
Sir J.J Road Byculla, Mumbai - 400 020

T + 91 22 23781457 / 23781382
F + 91 22 23780915
E-mail: mumbai@rm.beml.co.in

Nagpur

33, Cement Road,
Shivaji Nagar,
Nagpur - 440 010, Maharashtra.

T + 91 0712 2248435 / 2248343
F + 91 0712 2249997
E-mail: nagpur@rm.beml.co.in

New Delhi

Flat EFGH, 'Vandana', 11th Floor,
Tolstoy Marg,
New Delhi - 110 001

T + 91 11 23310035 / 23316500
F + 91 11 23325085
E-mail: delhi@rm.beml.co.in

Ranchi

206/D-1, Bhagirathi, (Behind NCC Campus),
Rameshwaram Colony, Bariatu Road,
Ranchi, Jharkhand - 834009

T + 91 651 2540710 / 2540791
F + 91 651 2540624
E-mail: ranchi@rm.beml.co.in

Sambalpur

BEML Complex, NH-6, Baraipalli,
Sambalpur - 768 150
Orissa.

T + 91 663 2521604 / 2520393
F + 91 663 2521603
E-mail: sambalpur@rm.beml.co.in

Singrauli

PB No. 5, Jhingurdha Colliery,
Sidhi, Singrauli - 486 889
Madhya Pradesh.

T + 91 7805 268260 / 266668
F + 91 7805 267282 / 318
E-mail: singrauli@rm.beml.co.in

DISTRICT OFFICES

Ahmedabad

266-1, Dilbaug Villa,
Darshan Society Road, Navrangpura,
Ahmedabad - 380 009. Gujarat

T + 91 79 26445523
F + 91 79 26423950
E-mail: ahmedabad@rm.beml.co.in

Asansol

3, Bumpur Road,
Asansol - 713 304
West Bengal

T + 91 341 2252480
F + 91 341 2250601
E-mail: asansol@rm.beml.co.in

Bacheli

Behind Central Stores
of NMDC Ltd., Depot 5, Bacheli - 494 553.
Chhattisgarh

T + 91 7857 200518
F + 91 7857 230005
E-mail: bacheli@rm.beml.co.in

Bhopal

Ground Floor, Hall No.1, Chittod Complex
Zone-1, Maharana Pratap Nagar (MP Nagar)
Bhopal - 462 023

T + 91 755 2550711
E-mail: bemlbhopal@gmail.com

DISTRICT OFFICES

Bhubaneswar

252/A, LEWIS Road,
Bhubaneswar - 751 014
Orissa

T + 91 674 2434428
T/F + 91 674 2434427
E-mail: bhuvaneshwar@rm.beml.co.in

Chandrapur

Mamidwar, Tiles Factory Compound,
Ghugus Road, Padoli,
Chandrapur - 442 406 Maharashtra

T + 91 7172 287230
F + 91 7172 287072
E-mail: chandrapur@rm.beml.co.in

Cochin

No. 55/845, Chittor Road, Ernakulam South
Cochin-682 016

T + 91 484 2375138
E-mail: bemlkochi@gmail.com

GOA

67-12, Dattaprasad Building, 3rd Floor, MG road
Timphoni School, Panjim, - 403001, Goa

T + 91 832 2225135
E-mail: goa@rm.beml.co.in

Guwahati

Hegrabari Road, House No. 11,
Ganesh Puri, Dispur,
Guwahati - 781 006 Assam

T + 91 361 2232966
F + 91 361 2232967
E-mail: guwahati@rm.beml.co.in

Hospet

No. 1431, Manjunatha Complex, New Ward No. 31,
Bhagat Singh Nagar, Opp. KSSIDC Indl. Estate,
Dam Road, Hospet - 583 203, Karnataka

T + 91 8394 230173
F + 91 8394 230172
E-mail: hospet@rm.beml.co.in

Jammu

62C, Block D/C, Gandhi Nagar,
Jammu tawi - 180 004
Jammu and Kashmir

T + 91 191 2430447
F + 91 191 2477469
E-mail: jammu@rm.beml.co.in

Kothagudem

Old Project Planning Department,
Near SCCL Corporate Office,
Kothagudem - 507 101, Andhra Pradesh

T + 91 8744 245572
F + 91 8744 245530
E-mail: kothagudem@rm.beml.co.in

LEH

#135, Fort Road, Sheynam
LEH, Ladakh, 194 101

T + 91 9622973460
E-mail: bemlleh@gmail.com

Madurai

9-4/49, Kalai Nagar, IInd Main Road,
Madurai - 625 017, Tamil Nadu.

T/F + 91 452 2649458
E-mail: madurai@rm.beml.co.in

Neyveli

F-4, Rajendraprasad Road, Block-27
Neyveli - 607 803, Tamil Nadu

T/F + 91 4142 268517
E-mail: neyveli@rm.beml.co.in

Panjim

67-12, Dattaprasad Building, III Floor, MG Road,
Timphoni School, Panjim - 403 001, Goa

T/F + 91 832 2225135
E-mail: goa@rm.beml.co.in

Ramagundam

Opp. SCCL 11A Mines, Manthani,
(PO) Jallaram, GK - 505 184
Karimnagar Dt. Andhra Pradesh

T + 91 8728 248299
F + 91 8728 247423
E-mail: ramagundam@rm.beml.co.in

Udaipur

20-B Uchhaba Bhawan, Bedia Road,
New Fatehpura, Udaipur - 313 001.
Rajasthan

T + 91 294 2452053, 2452055
F + 91 294 2452054
E-mail: udaipur@rm.beml.co.in

Vijayawada

District Manager : Mr Rambabu

Mob +91 8330930990

Visakhapatnam

No. 8-45-11, 4h Lane, China Waltair Colony,
Visakhapatnam - 530 003

T/F 0891 2754608
E-mail: vizag@rm.beml.co.in

www.bemlindia.com

Represented by :

बी ई एम एल लिमिटेड BEML LIMITED

A Govt. of India Miniratna Company Under Ministry of Defence