

# BD80

CRAWLER DOZER



## Salient Features :

- Turbocharged BEML BS6D125-1
- Helical Gear, Constant mesh, Hand Operated Transmission
- Sturdy Construction of Chassis & Track frame
- Groove type Floating Seals in all rollers



# BD80

Flywheel horsepower (net) : 134 kW (180 HP)  
@ 1850 rpm

Operating mass : 21550 kg  
(with Angle dozer )

# BD80

## CRAWLER DOZER

### Salient Features :

- BEML BS6D125-1 Direct-injection type Diesel engine for sustained power and economy.
- Sturdy box type construction Main frame designed to withstand shocks and stresses of heavy dozer work.
- Hydraulically actuated, oil cooled main clutch
- Heavy duty, constant mesh transmission with helical gears.
- Hydraulically actuated, self-adjusting oil cooled steering clutches for long life. Steering brakes are also oil cooled.
- Hydraulically controlled dozer blade with fully ribbed mould board.
- Floating - seals in all rollers, idlers and sprockets.
- Special dust seals for prevention of abrasive dirt entry into the pin and link bushing clearances which ensures longer track services.



### ENGINE

Make	BEML
Model	BS6D125-1
Type	Water cooled 4 cycle, Turbo charged, direct injection diesel engine.
No. of cylinders	6, inline
Bore x Stroke	Dia 125 x 150 mm
Displacement	0.01100m <sup>3</sup> (11.00ℓ)
<b>Horse Power</b>	
Rated bhp*	143 kW (196 HP) @ 1850 rpm
Fly wheel power **	134 kW (180 HP) @ 1850 rpm
Maximum torque	784.8 Nm @ 1100 rpm
<b>Fuel System</b>	
Type	Bosch type, FIP system
Governor	Mechanical, all speed control
<b>Lubrication System</b>	
Method	Forced lubrication
Pump	Gear pump
Filter	Full flow
Oil Cooler	Water cooled
<b>Cooling System</b>	
Type	Centrifugal water pump pusher type fan
<b>Air Cleaner</b>	
Type	Dry, horizontal type
<b>Electricals</b>	
Alternator	24 V, 55A
Starting motor	24 V, 7.5 kW

\* Rated bhp is the output of the engine as installed in the machine at governed rpm and with engine manufacturer's approved fuel setting. Accessory losses included are water pump, fuel pump and lube oil pump. Output guaranteed within ± 5%

\*\* Flywheel power is the rated bhp less the average accessory losses. Accessories included are fan, alternator and hydraulic pump at no load.



### POWER TRAIN

<b>Transmission System</b>	Direct drive		
<b>Main Clutch</b>			
Type	Wet, multiple disc overcenter engagement, hand operated with intertia brake and hydraulic booster		
<b>Transmission</b>			
Type	Helical gear, constant mesh, hand operated		
Bevel gear	Spiral type, single reduction		
<b>Final Drive</b>			
Type	Spur gear, double reduction		
Reduction ratio	17.187		
Gear Shift	5 Forward, 4 Reverse		
<b>Travel speeds km/h</b>			
Range	Forward	Drawbar - Pull (kg)	Reverse
1st	0-2.4	17,250	0-3.1
2nd	0-3.4	12,180	0-4.5
3rd	0-5.2	7,960	0-6.7
4th	0-7.4	5,600	0-9.6
5th	0-10.0	4,160	

### STANDARD ACCESSORIES

Ammeter	Water temperature gauge
Tacho hour meter	Tool kit
Head lamps & rear lamp	High water temperature Indicator
24V, 55 A alternator	Low engine oil pressure indicator
Warning lamp	Light switch
Engine oil pressure gauge	Canvas canopy

### OPTIONAL ATTACHMENTS

Steel Cabin	Straight Dozer
Steel top canopy	Straight Tilt Dozer
Rake dozer straight	Multi Shank Ripper

### COAL DOZER

Towing winch	Drawbar fixed type
Dozer for steel mill	Track shoe of width 610 mm
Pusher plate	Track shoe of width 660 mm
	Preheater



## HYDRAULIC SYSTEM

### Hydraulic Pump

Type	Gear pump
Capacity	269 ℓ / min @ 1850 r/min
Relief pressure	13.73 MPa (140 kg/cm <sup>2</sup> )

### Hydraulic Cylinders

Type	Double acting piston
Blade Lift	2 cylinders
Bore x Stroke	Dia120 x 1014 mm



## STEERING

### Steering clutch

Type	Wet, multiple disc hydraulic, together with spring type booster
Control	Hand operated with back - up booster

### Steering Brake

Type	Wet, contracting band
Control	Foot operated supported by efficient linkages for light touch actuation.



## UNDER CARRIAGE

Suspension	Semi-rigid equalizer bar type
Track frame	Box-section, high tensile strength steel construction
Track rollers	6 nos. each side
Carrier rollers	2 nos. each side

### Track shoes

Type	Assembled, single grouser
Grouser height	65 mm
Shoe with	560 mm
No. of shoes	38 nos. on each side
Ground pressure (Tractor only)	0.58 kg/cm <sup>2</sup>
Ground contact area	30576 cm <sup>2</sup>



## OPERATING MASS

Operating mass - Tractor only (Including rated capacity of lubricant, coolant and fuel) **17630 kg**

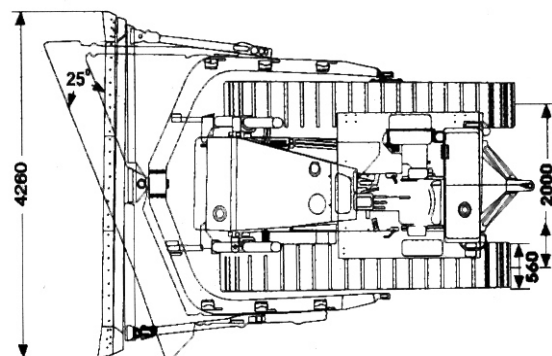

Ground Clearance - 400 mm

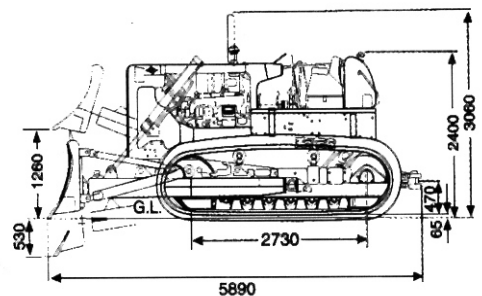
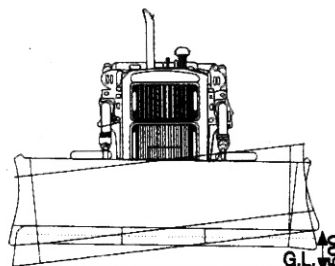

Material and specifications are subject to change without notice, Illustrations may include optional equipment & accessories



## DOZER EQUIPMENT

	Angle Dozer	Straight Tilt dozer	Coal dozer
Over length with dozer (mm)	5890	5660	6000
Blade length x height (mm)	4260 x 1080	3460 x 1280	4450 x 1540
Max. life above ground (mm)	1260	1175	1275
Max. drop below ground (mm)	530	610	535
Max. tilt adjustment (mm)	500	735	*
Additional ground pressure kPa (kg/cm <sup>2</sup> )	0.13	0.11	0.13
<b>Mass (kg)</b>			
Blade	3470	2880	3540
Hydraulic Control Unit	450	450	450

\* Tilt cylinder for coal dozer is optional



## COOLANT & LUBRICANT

System (Refilling)	Capacity in ℓ
Crank case	32
Fuel Tank	420
Cooling System	65
Transmission (including steering system)	75
Final drive (each side)	36
Hydraulic tank	105
Main clutch	25



## DRAWBAR PULL

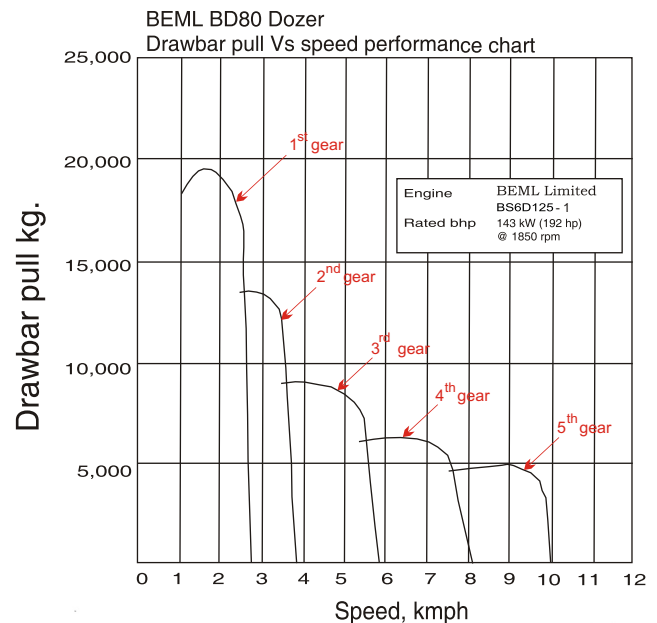

# बी ई एम एल लिमिटेड BEML LIMITED

A Govt. of India Miniratna Company Under Ministry of Defence

## Business Network

### Corporate Office

BEML Soudha, 23/1, 4th Main,  
S.R. Nagar, Bangalore-560 027

T + 91 80 22963240, 22963250

F + 91 80 22963278/516/280/164

E-mail: office@cpd.beml.co.in  
office@pr.beml.co.in

### International Business Division

BEML Soudha, 23/1, 4th Main,  
S.R. Nagar, Bangalore-560 027

T + 91 80 22222730, 22233350  
22963187, 22963215

F + 91 80 22224874

E-mail: office@export.beml.co.in

### Marketing Division

5th Floor, Unity Building,  
J.C. Road, Bangalore-560 002

T + 91 80 22963501/02/07/510/553

F + 91 80 22963541

E-mail: m@beml.co.in  
bemldealer@dealer.beml.co.in

### Global Service HQ

C-6, Central Hingna Road,  
MIDC Industrial Area, Hingna,  
Nagpur-440 028

T + 91 7104 287097/287098

F + 91 7104 287099

E-mail: ss.servicehq@gmail.com  
ss@servicehq.beml.co.in

## REGIONAL OFFICES

### Bangalore

No -23/1, Haudin Road Cross,  
Ulsoor Road, Bangalore - 560008  
Karnataka

T + 91 080 22963590/92/93/94  
F + 91 080 2558156  
E-mail: mg@beml.co.in

### Bilaspur

1/A, Sector-C, Srigitti Industrial Area,  
P.O: Tifra, Bilaspur - 495 223.  
Chhattisgarh.

T + 91 7752 252745, 252598  
F + 91 7752 252065  
E-mail: bilaspur@rm.beml.co.in

### Chennai

Flat No. 10&11, Supriya Estates,  
Sterling Road, Nungambakkam,  
Chennai - 600 034, Tamil Nadu

T + 91 44 28276576 / 22820844  
F + 91 44 28257319  
E-mail: chennai@rm.beml.co.in

### Dhanbad

Kamal Kunj, Kola Kusuma,  
Saraidhela, Dhanbad - 828 127  
Jharkhand

T + 91 326 2200180 / 2208982/5827  
F + 91 326 2200182  
E-mail: dhanbad@rm.beml.co.in

### Hyderabad

3-6-114, Himayat Nagar,  
Hyderabad - 500 029  
Andhra Pradesh

T + 91 40 23225250 / 7032 / 2166  
F + 91 40 23221794  
E-mail: hyderabad@rm.beml.co.in

### Kolkata

35/1, Taratala Road,  
Kolkata - 700 088.  
West Bengal

T + 91 33 24015286 / 87 / 98 / 99  
F + 91 33 24015288  
E-mail: kolkata@rm.beml.co.in

### Mumbai

C/o Richardson & Cruddas (1972) Ltd.  
3rd Floor, Corporate Office Building  
Sir J.J Road Byculla, Mumbai - 400 020

T + 91 22 23781457 / 23781382  
F + 91 22 23780915  
E-mail: mumbai@rm.beml.co.in

### Nagpur

33, Cement Road,  
Shivaji Nagar,  
Nagpur - 440 010, Maharashtra.

T + 91 0712 2248435 / 2248343  
F + 91 0712 2249997  
E-mail: nagpur@rm.beml.co.in

### New Delhi

Flat EFGH, 'Vandana', 11th Floor,  
Tolstoy Marg,  
New Delhi - 110 001

T + 91 11 23310035 / 23316500  
F + 91 11 23325085  
E-mail: delhi@rm.beml.co.in

### Ranchi

206/D-1, Bhagirathi, (Behind NCC Campus),  
Rameshwaram Colony, Bariatu Road,  
Ranchi, Jharkhand - 834009

T + 91 651 2540710 / 2540791  
F + 91 651 2540624  
E-mail: ranchi@rm.beml.co.in

### Sambalpur

BEML Complex, NH-6, Baraipalli,  
Sambalpur - 768 150  
Orissa.

T + 91 663 2521604 / 2520393  
F + 91 663 2521603  
E-mail: sambalpur@rm.beml.co.in

### Singrauli

PB No. 5, Jhingurdha Colliery,  
Sidhi, Singrauli - 486 889  
Madhya Pradesh.

T + 91 7805 268260 / 266668  
F + 91 7805 267282 / 318  
E-mail: singrauli@rm.beml.co.in

## DISTRICT OFFICES

### Ahmedabad

266-1, Dilbaug Villa,  
Darshan Society Road, Navrangpura,  
Ahmedabad - 380 009. Gujarat

T + 91 79 26445523  
F + 91 79 26423950  
E-mail: ahmedabad@rm.beml.co.in

### Asansol

3, Bumpur Road,  
Asansol - 713 304  
West Bengal

T + 91 341 2252480  
F + 91 341 2250601  
E-mail: asansol@rm.beml.co.in

### Bacheli

Behind Central Stores  
of NMDC Ltd., Depot 5, Bacheli - 494 553.  
Chhattisgarh

T + 91 7857 200518  
F + 91 7857 230005  
E-mail: bacheli@rm.beml.co.in

### Bhopal

Ground Floor, Hall No.1, Chittod Complex  
Zone-1, Maharana Pratap Nagar (MP Nagar)  
Bhopal - 462 023

T + 91 755 2550711  
E-mail: bemlbhopal@gmail.com

## DISTRICT OFFICES

### Bhubaneswar

252/A, LEWIS Road,  
Bhubaneswar - 751 014  
Orissa

T + 91 674 2434428  
T/F + 91 674 2434427  
E-mail: bhuvaneshwar@rm.beml.co.in

### Chandrapur

Mamidwar, Tiles Factory Compound,  
Ghugus Road, Padoli,  
Chandrapur - 442 406 Maharashtra

T + 91 7172 287230  
F + 91 7172 287072  
E-mail: chandrapur@rm.beml.co.in

### Cochin

No. 55/845, Chittor Road, Ernakulam South  
Cochin-682 016

T + 91 484 2375138  
E-mail: bemlkochi@gmail.com

### GOA

67-12, Dattaprasad Building, 3rd Floor, MG road  
Timphoni School, Panjim, - 403001, Goa

T + 91 832 2225135  
E-mail: goa@rm.beml.co.in

### Guwahati

Hegrabari Road, House No. 11,  
Ganesh Puri, Dispur,  
Guwahati - 781 006 Assam

T + 91 361 2232966  
F + 91 361 2232967  
E-mail: guwahati@rm.beml.co.in

### Hospet

No. 1431, Manjunatha Complex, New Ward No. 31,  
Bhagat Singh Nagar, Opp. KSSIDC Indl. Estate,  
Dam Road, Hospet - 583 203, Karnataka

T + 91 8394 230173  
F + 91 8394 230172  
E-mail: hospet@rm.beml.co.in

### Jammu

62C, Block D/C, Gandhi Nagar,  
Jammu tawi - 180 004  
Jammu and Kashmir

T + 91 191 2430447  
F + 91 191 2477469  
E-mail: jammu@rm.beml.co.in

### Kothagudem

Old Project Planning Department,  
Near SCCL Corporate Office,  
Kothagudem - 507 101, Andhra Pradesh

T + 91 8744 245572  
F + 91 8744 245530  
E-mail: kothagudem@rm.beml.co.in

### LEH

#135, Fort Road, Sheynam  
LEH, Ladakh, 194 101

T + 91 9622973460  
E-mail: bemlleh@gmail.com

### Madurai

9-4/49, Kalai Nagar, IInd Main Road,  
Madurai - 625 017, Tamil Nadu.

T/F + 91 452 2649458  
E-mail: madurai@rm.beml.co.in

### Neyveli

F-4, Rajendraprasad Road, Block-27  
Neyveli - 607 803, Tamil Nadu

T/F + 91 4142 268517  
E-mail: neyveli@rm.beml.co.in

### Panjim

67-12, Dattaprasad Building, III Floor, MG Road,  
Timphoni School, Panjim - 403 001, Goa

T/F 91 832 2225135  
E-mail: goa@rm.beml.co.in

### Ramagundam

Opp. SCCL 11A Mines, Manthani,  
(PO) Jallaram, GK - 505 184  
Karimnagar Dt. Andhra Pradesh

T + 91 8728 248299  
F + 91 8728 247423  
E-mail: ramagundam@rm.beml.co.in

### Udaipur

20-B Uchhaba Bhawan, Bedia Road,  
New Fatehpura, Udaipur - 313 001.  
Rajasthan

T + 91 294 2452053, 2452055  
F + 91 294 2452054  
E-mail: udaipur@rm.beml.co.in

### Vijayawada

District Manager : Mr Rambabu

Mob +91 8330930990

### Visakhapatnam

No. 8-45-11, 4h Lane, China Waltair Colony,  
Visakhapatnam - 530 003

T/F 0891 2754608  
E-mail: vizag@rm.beml.co.in

## www.bemlindia.com

Represented by :

# बी ई एम एल लिमिटेड BEML LIMITED

A Govt. of India Miniratna Company Under Ministry of Defence