

BD85

CRAWLER DOZER



Salient Features :

- BEML Turbocharged BS6D125-1 Engine
- Power shift Transmission.
- Wet steering Clutches and Brakes.
- Arm chair steering control.
- ⊗ Longer track for better stability and improved traction.
- Durable work attachment.
- Segmented sprockets
- Hexagonal Steel Cabin



BD85

Flywheel Power (FHP) : 172 kW (230 HP) @ 2000 rpm

Operating Mass : 24340 kg
(With Straight tilt Dozer)

BD85

CRAWLER DOZER

Salient Features :

BEML BS6D125 Engine: Engine is environment friendly as it ensures low level of vibration, noise and smoke.

Power Shift Transmission : Smooth and responsive power shift with single lever control for instant speed and directional changes.

Control Panel: Modular type gauges with cluster packaged monitoring system.

Operator Comfort : Ergonomically located armchair steering control for enhanced operator comfort with Hexagonal sound suppressed cabin provides excellent visibility.

Longer track for better stability and improved traction.

Wet multiple disc steering clutches and brakes : Hydraulically inter linked steering clutch and brakes provide excellent maneuverability during gradual and pivot turns.

Higher drawbar pull and higher speeds for enhanced productivity.

Durable work attachment : High tensile steel blades of different configurations available to suit varying types of working conditions and applications.

The attachment is sturdy in construction to withstand adverse ground conditions.

Rugged driveline components for reliability and longer life.



ENGINE

Make	BEML
Model	BS6D125-1
Type	6 inline Diesel 4 stroke, water cooled, turbo charged, direct injection
Fly wheel Power	172 kW (230 HP) @ 2000 rpm
Max. Torque	1010 N-m (103 kg-m) at 1400 rpm
No. of Cylinders	6, inline
Bore x Stroke	Dia.125 x 150 mm
Displacement	11.04 ℓ (0.01104 m ³)
ELECTRICALS	
Alternator	24V, 55A
Starting Motor	24V, 7.5kW
Battery	2 x 12V, 200Ah



POWER TRAIN

TORQUE CONVERTER	
Stall ratio	2.2
Type	3 element, Single Stage, Single phase,

TRANSMISSION	
Type	3F/3R, Power shift Transmission



FINAL DRIVE

Type	Spiral bevel gear, Single reduction
Lubrication	Splash Type
Total Reduction	17.19

TRAVEL SPEEDS m/sec (km/h)		
Range	Forward	Reverse
1st	0-0.972 (0-3.60)	0-1.134 (0-4.20)
2nd	0-1.809 (0-6.70)	0-2.187 (0-8.10)
3rd	0-3.186 (0-11.8)	0.3.834 (0-14.2)



HYDRAULIC SYSTEM

Hydraulic Pump	
Type	Gear pump
Capacity	245 lpm
Relief Pressure	13.73 MPa (140 kg/cm ²)

Hydraulic Cylinder	
Type	Double acting piston type
Blade Lift	2 Cylinder
Bore x Stroke	Dia 120 mm x 1014 mm
Blade Tilt	1 Cylinder
Bore x Stroke	Dia 160 mm x 140 mm

STANDARD EQUIPMENT

Hydraulic Track Adjusters
 Air cleaner inner element lock
 Track roller guard (each side)
 Front Horn
 Lower guard (3 pieces)
 Fixed type draw bar
 Head light & rear light, Gauge lamp switches.
 Front pull hook
 In-line radiator
 Tool kit
 Audio visual backup alarm
 Lighting system (including 4 front and 1 rear lights)
 Straight Tilt Blade
 Hexagonal ROPS / FOPS Cabin

CONTROL LEVERS

Steering (Right)
 Steering (left)
 Gear-shift
 Safety lock for gear shift
 Blade control (Joystick)
 Fuel control lever
 Brake lock lever
 Safety lock for blade

MONITORING & ALARM SYSTEM

Safety lock for blade lever
 Transmission lock lever
 In a single LCD Display: Torque converter oil temperature, Engine oil pressure, Engine hour meter, Voltmeter, Engine speed, Fuel level & Engine coolant temperature provided.
 Warning lamps for abnormalities, battery charging and Radiator water level caution indications in display unit
 Dust indicator
 Smart reverse alarm with flasher unit

OPTIONAL ATTACHMENTS

AC with heater
 Multi Shank Ripper
 Angle dozer Blade attachment
 SU Blade
 Coal Dozer Blade
 ROPS Canopy with sweeper for Forestry application



STEERING

Type	Wet, multiple disc hydraulic booster, hand operated
Min. Turning radius	3.3 m
Steering Control	Arm Chair steering lever



UNDER CARRIAGE

Suspension	Semi rigid Equalizer bar type
Track Frame	Box section, high tensile strength steel construction.
Track Pitch	2000 mm
Track Rollers	7 no. each side
Carrier Rollers	2 no. each side
Track Shoes	41 no. each side
Grouser Height	65 mm
Shoe Type	Single grouser
Shoe width	560 mm
Ground Press	66.13 kPa (0.67 kg/cm ²)(Bare tractor)
Ground contact Area	3.6065m ²



FILTRATION

Engine:	Replaceable cartridge type filter for lubrication as well as for fuel line.
Transmission, Torque converter, Steering & Brake:	One common Magnetic oil strainer is provided
Transmission, Torque converter, Steering & Brake:	Separate replaceable element type filter is provided
Hydraulic System:	Magnetic iron particles separator & return line filters.



MASS (approximate)

Operating Mass (Standard equipment with straight tilt dozer)	24340kg
Shipping Mass (Basic tractor with lubricants, Hydraulic system, cooling system and 10% of fuel tank capacity)	21420 kg



DOZER ATTACHMENT

Dozer type	Straight	Angle	Semi-U	Coal
Overall length with dozer	5915	6215	5950	6565
Blade Length x Height	3465 x 1380	4260 x 1125	3810 x 1550	4450 x 1540
Max. Lift above ground	1350	1040	1385	1625
Max. drop below ground	620	740	620	545
Max. tilt adjustment	860	600	860	-
Blade Capacity (Cum)	4.50	4.31	7.50	10.10
Additional ground pressure kPa (kg/cm ²)	8.83 (0.087)	9.41 (0.096)	(0.095)	9.63 (0.098)
MASS in kg				
Dozer Equipment	2990	3470	3440	3540
Hydraulic control unit	450	450	450	450

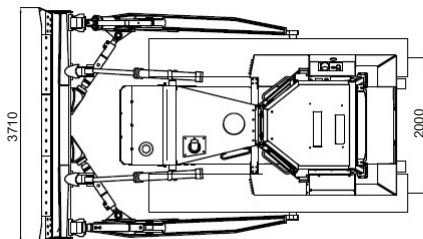

SYSTEM FLUID CAPACITY

System	Refill Capacity ltrs.
Cooling System	88
Fuel Tank	385
Engine Oil Pan	32
Trx. Bevel Gear	135
Torque Converter Steering	
Final Drive (each side)	36
Hydraulic Oil	114.5



BRAKE

Type	Wet, Contracting Band
Actuation Type	Foot operated Mechanical linkage assisted by hydraulic booster for light touch and easy actuation. Brakes and steering clutches are hydraulically interconnected for easy steering.



CABIN

Hexagonal shaped, sound suppressive ROPS / FOPS cabin provides excellent visibility and operator comfort.



DRAW BAR PULL vs TRAVEL SPEED

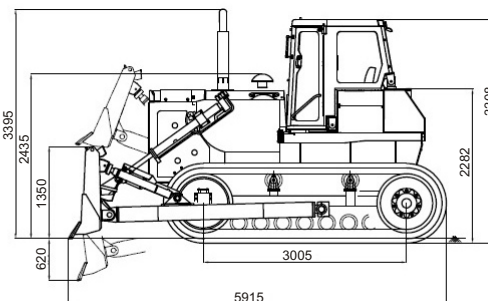
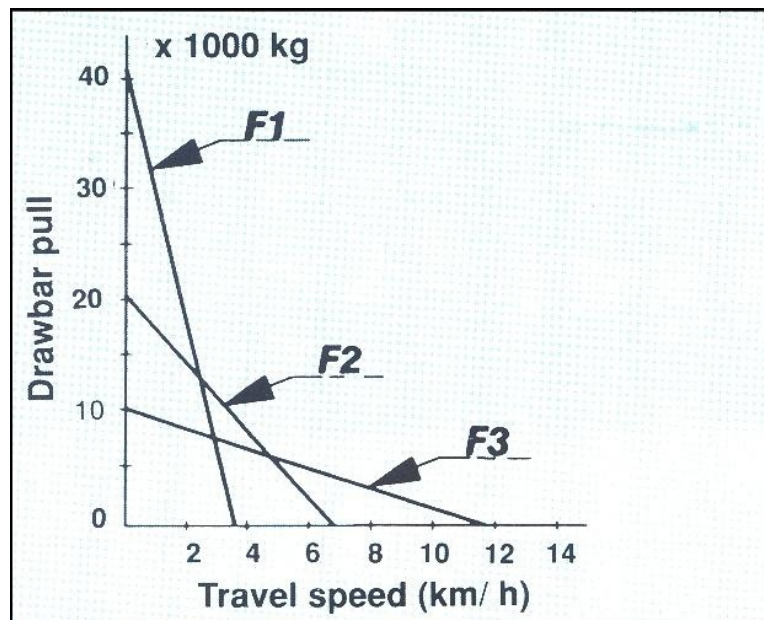

बी ई एम एल लिमिटेड BEML LIMITED

A Govt. of India Miniratna Company Under Ministry of Defence

Business Network

Corporate Office

BEML Soudha, 23/1, 4th Main,
S.R. Nagar, Bangalore-560 027

T + 91 80 22963240, 22963250

F + 91 80 22963278/516/280/164

E-mail: office@cpd.beml.co.in
office@pr.beml.co.in

International Business Division

BEML Soudha, 23/1, 4th Main,
S.R. Nagar, Bangalore-560 027

T + 91 80 22222730, 22233350
22963187, 22963215

F + 91 80 22224874

E-mail: office@export.beml.co.in

Marketing Division

5th Floor, Unity Building,
J.C. Road, Bangalore-560 002

T + 91 80 22963501/02/07/510/553

F + 91 80 22963541

E-mail: m@beml.co.in
bemldealer@dealer.beml.co.in

Global Service HQ

C-6, Central Hingna Road,
MIDC Industrial Area, Hingna,
Nagpur-440 028

T + 91 7104 287097/287098

F + 91 7104 287099

E-mail: ss.servicehq@gmail.com
ss@servicehq.beml.co.in

REGIONAL OFFICES

Bangalore

No -23/1, Haudin Road Cross,
Ulsoor Road, Bangalore - 560008
Karnataka

T + 91 080 22963590/92/93/94
F + 91 080 2558156
E-mail: mg@beml.co.in

Bilaspur

1/A, Sector-C, Srigitti Industrial Area,
P.O: Tifra, Bilaspur - 495 223.
Chhattisgarh.

T + 91 7752 252745, 252598
F + 91 7752 252065
E-mail: bilaspur@rm.beml.co.in

Chennai

Flat No. 10&11, Supriya Estates,
Sterling Road, Nungambakkam,
Chennai - 600 034, Tamil Nadu

T + 91 44 28276576 / 22820844
F + 91 44 28257319
E-mail: chennai@rm.beml.co.in

Dhanbad

Kamal Kunj, Kola Kusuma,
Saraidhela, Dhanbad - 828 127
Jharkhand

T + 91 326 2200180 / 2208982/5827
F + 91 326 2200182
E-mail: dhanbad@rm.beml.co.in

Hyderabad

3-6-114, Himayat Nagar,
Hyderabad - 500 029
Andhra Pradesh

T + 91 40 23225250 / 7032 / 2166
F + 91 40 23221794
E-mail: hyderabad@rm.beml.co.in

Kolkata

35/1, Taratala Road,
Kolkata - 700 088.
West Bengal

T + 91 33 24015286 / 87 / 98 / 99
F + 91 33 24015288
E-mail: kolkata@rm.beml.co.in

Mumbai

C/o Richardson & Cruddas (1972) Ltd.
3rd Floor, Corporate Office Building
Sir J.J Road Byculla, Mumbai - 400 020

T + 91 22 23781457 / 23781382
F + 91 22 23780915
E-mail: mumbai@rm.beml.co.in

Nagpur

33, Cement Road,
Shivaji Nagar,
Nagpur - 440 010, Maharashtra.

T + 91 0712 2248435 / 2248343
F + 91 0712 2249997
E-mail: nagpur@rm.beml.co.in

New Delhi

Flat EFGH, 'Vandana', 11th Floor,
Tolstoy Marg,
New Delhi - 110 001

T + 91 11 23310035 / 23316500
F + 91 11 23325085
E-mail: delhi@rm.beml.co.in

Ranchi

206/D-1, Bhagirathi, (Behind NCC Campus),
Rameshwaram Colony, Bariatu Road,
Ranchi, Jharkhand - 834009

T + 91 651 2540710 / 2540791
F + 91 651 2540624
E-mail: ranchi@rm.beml.co.in

Sambalpur

BEML Complex, NH-6, Baraipalli,
Sambalpur - 768 150
Orissa.

T + 91 663 2521604 / 2520393
F + 91 663 2521603
E-mail: sambalpur@rm.beml.co.in

Singrauli

PB No. 5, Jhingurdha Colliery,
Sidhi, Singrauli - 486 889
Madhya Pradesh.

T + 91 7805 268260 / 266668
F + 91 7805 267282 / 318
E-mail: singrauli@rm.beml.co.in

DISTRICT OFFICES

Ahmedabad

266-1, Dilbaug Villa,
Darshan Society Road, Navrangpura,
Ahmedabad - 380 009. Gujarat

T + 91 79 26445523
F + 91 79 26423950
E-mail: ahmedabad@rm.beml.co.in

Asansol

3, Bumpur Road,
Asansol - 713 304
West Bengal

T + 91 341 2252480
F + 91 341 2250601
E-mail: asansol@rm.beml.co.in

Bacheli

Behind Central Stores
of NMDC Ltd., Depot 5, Bacheli - 494 553.
Chhattisgarh

T + 91 7857 200518
F + 91 7857 230005
E-mail: bacheli@rm.beml.co.in

Bhopal

Ground Floor, Hall No.1, Chittod Complex
Zone-1, Maharana Pratap Nagar (MP Nagar)
Bhopal - 462 023

T + 91 755 2550711
E-mail: bemlbhopal@gmail.com

DISTRICT OFFICES

Bhubaneswar

252/A, LEWIS Road,
Bhubaneswar - 751 014
Orissa

T + 91 674 2434428
T/F + 91 674 2434427
E-mail: bhuvaneshwar@rm.beml.co.in

Chandrapur

Mamidwar, Tiles Factory Compound,
Ghugus Road, Padoli,
Chandrapur - 442 406 Maharashtra

T + 91 7172 287230
F + 91 7172 287072
E-mail: chandrapur@rm.beml.co.in

Cochin

No. 55/845, Chittor Road, Ernakulam South
Cochin-682 016

T + 91 484 2375138
E-mail: bemlkochi@gmail.com

GOA

67-12, Dattaprasad Building, 3rd Floor, MG road
Timphoni School, Panjim, - 403001, Goa

T + 91 832 2225135
E-mail: goa@rm.beml.co.in

Guwahati

Hegrabari Road, House No. 11,
Ganesh Puri, Dispur,
Guwahati - 781 006 Assam

T + 91 361 2232966
F + 91 361 2232967
E-mail: guwahati@rm.beml.co.in

Hospet

No. 1431, Manjunatha Complex, New Ward No. 31,
Bhagat Singh Nagar, Opp. KSSIDC Indl. Estate,
Dam Road, Hospet - 583 203, Karnataka

T + 91 8394 230173
F + 91 8394 230172
E-mail: hospet@rm.beml.co.in

Jammu

62C, Block D/C, Gandhi Nagar,
Jammu tawi - 180 004
Jammu and Kashmir

T + 91 191 2430447
F + 91 191 2477469
E-mail: jammu@rm.beml.co.in

Kothagudem

Old Project Planning Department,
Near SCCL Corporate Office,
Kothagudem - 507 101, Andhra Pradesh

T + 91 8744 245572
F + 91 8744 245530
E-mail: kothagudem@rm.beml.co.in

LEH

#135, Fort Road, Sheynam
LEH, Ladakh, 194 101

T + 91 9622973460
E-mail: bemlleh@gmail.com

Madurai

9-4/49, Kalai Nagar, IInd Main Road,
Madurai - 625 017, Tamil Nadu.

T/F + 91 452 2649458
E-mail: madurai@rm.beml.co.in

Neyveli

F-4, Rajendraprasad Road, Block-27
Neyveli - 607 803, Tamil Nadu

T/F + 91 4142 268517
E-mail: neyveli@rm.beml.co.in

Panjim

67-12, Dattaprasad Building, III Floor, MG Road,
Timphoni School, Panjim - 403 001, Goa

T/F + 91 832 2225135
E-mail: goa@rm.beml.co.in

Ramagundam

Opp. SCCL 11A Mines, Manthani,
(PO) Jallaram, GK - 505 184
Karimnagar Dt. Andhra Pradesh

T + 91 8728 248299
F + 91 8728 247423
E-mail: ramagundam@rm.beml.co.in

Udaipur

20-B Uchhaba Bhawan, Bedia Road,
New Fatehpura, Udaipur - 313 001.
Rajasthan

T + 91 294 2452053, 2452055
F + 91 294 2452054
E-mail: udaipur@rm.beml.co.in

Vijayawada

District Manager : Mr Rambabu

Mob +91 8330930990

Visakhapatnam

No. 8-45-11, 4h Lane, China Waltair Colony,
Visakhapatnam - 530 003

T/F 0891 2754608
E-mail: vizag@rm.beml.co.in

www.bemlindia.com

Represented by :

बी ई एम एल लिमिटेड BEML LIMITED

A Govt. of India Miniratna Company Under Ministry of Defence